



EL-ELITE ARCHITECTURAL Series Fire Extinguisher Cabinets (Non-Rated)

Detail & Submittal Sheet

Construction Specifications:

ELITE (EL) Cabinet is 16 gauge cold rolled steel with 22 gauge cold rolled steel tubs. Fronts are white baked enamel. All cabinets come standard with chrome D handles and clear acrylic glazing.

To comply with ADA Guidelines, Extinguishers and Cabinets offer handles, brackets and turnbacks according to instructions provided by installer. For ADA compliance follow the specification ordering process dimensions in our catalog. Proper installation in accordance with the ADA Guidelines is the sole responsibility of the installer. For more information please visit the Accessibility Guidelines for Buildings and Facilities website or call them at 1-800-872-2253.

Project: _____
 Specification Reference: _____
 Model Number: _____ Quantity: _____
 Architect: _____
 Contractor: _____
 Distributor: _____
 Approved By: _____
 Date: _____

SPECIFICATION PROCESS: Follow the steps below to specify your cabinet. Options at additional cost.

STEP 1: EXTINGUISHER

SIZE:
 5 - 5 lb. 1 - 10 lb. 2 - 20 lb.

STEP 2: CABINET STYLE:

- 0 - Surface Mounted (S)
- 1 - Semi-Recessed (SR)
- 2 - Fully-Recessed (FR)

STEP 3: DOOR STYLE:

- 6 - Full Glass (FG)
- 7 - Full Metal (FM)
- 8 - Vertical Duo (VD)

STEP 4: SERIES:

EL - Elite Architectural

STEP 5: CABINET TYPE:

Non-Fire Rated

STEP 6: FINISH OPTIONS:

- SSF - Stainless Steel Front, #4 finish: 304 (standard) or 316** (optional)

- FSS - Full Stainless Steel, #4 finish: 304 (standard) 316** (optional)
- WH - Baked White Enamel
- RD - Baked Red Enamel
- BK - Baked Black Enamel

STEP 7: HANDLE/ACCESSORY OPTIONS:

- 007 - Chrome "D" Handle (Standard)
- 008 - Chrome "D" Handle w/Safety Break Glass
- 010 - Aluminum Die Cast Red "Fire" Handle
- 012 - ADA "Recessed" Handle

STEP 8: GLAZING:

- G11 - Clear Acrylic (Standard)
- G12 - Clear Tempered Glass

STEP 9: LETTERING:

- 004 - Decal "Fire Ext." Vertical R/B

Options



CHROME "D" HANDLE (STANDARD)



CHROME "D" HANDLE W/ SAFETY BREAK LOCK



ALUMINUM DIE CAST RED "FIRE" HANDLE



ADA "RECESSED" HANDLE

FIRE EXTINGUISHER

FIRE EXTINGUISHER

BuyOnline

How to Measure a Cabinet

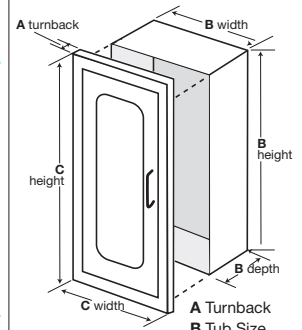

A Turnback
 B Tub Size
 C Overall Outside Trim

| ✓ | Mod. # | Interior Tub Size | | | Overall Outside Trim | | Rough Opening | | | Turnback | Accom. Ext Size Lbs. | |
|------------------------|--------|-------------------|-----|----|----------------------|---------|---------------|---------|--------|----------|----------------------|---|
| | | W | H | D | W | H | W | H | D | | | |
| Surface Mounted | | | | | | | | | | | | |
| | 506-EL | 8" | 17" | 5" | 8 1/2" | 17 1/2" | - | - | - | - | 5 | - |
| | 507-EL | 8" | 17" | 5" | 8 1/2" | 17 1/2" | - | - | - | - | 5 | - |
| | 508-EL | 8" | 17" | 5" | 8 1/2" | 17 1/2" | - | - | - | - | 5 | - |
| | 106-EL | 9 1/2" | 24" | 6" | 10" | 24 1/2" | - | - | - | - | 10 | - |
| | 107-EL | 9 1/2" | 24" | 6" | 10" | 24 1/2" | - | - | - | - | 10 | - |
| | 108-EL | 9 1/2" | 24" | 6" | 10" | 24 1/2" | - | - | - | - | 10 | - |
| | 206-EL | 12" | 27" | 8" | 12 1/2" | 27 1/2" | - | - | - | - | 20 | - |
| | 207-EL | 12" | 27" | 8" | 12 1/2" | 27 1/2" | - | - | - | - | 20 | - |
| | 208-EL | 12" | 27" | 8" | 12 1/2" | 27 1/2" | - | - | - | - | 20 | - |
| Semi-Recessed | | | | | | | | | | | | |
| | 516-EL | 8" | 17" | 5" | 10 3/4" | 19 3/4" | 8 1/4" | 17 1/4" | 3 1/2" | 1 3/4" | 5 | ✓ |
| | 517-EL | 8" | 17" | 5" | 10 3/4" | 19 3/4" | 8 1/4" | 17 1/4" | 3 1/2" | 1 3/4" | 5 | ✓ |
| | 518-EL | 8" | 17" | 5" | 10 3/4" | 19 3/4" | 8 1/4" | 17 1/4" | 3 1/2" | 1 3/4" | 5 | ✓ |
| | 116-EL | 9 1/2" | 24" | 6" | 13 1/2" | 28 1/2" | 9 3/4" | 24 1/4" | 3 1/2" | 2 1/2" | 10 | ✓ |
| | 117-EL | 9 1/2" | 24" | 6" | 13 1/2" | 28 1/2" | 9 3/4" | 24 1/4" | 3 1/2" | 2 1/2" | 10 | ✓ |
| | 118-EL | 9 1/2" | 24" | 6" | 13 1/2" | 28 1/2" | 9 3/4" | 24 1/4" | 3 1/2" | 2 1/2" | 10 | ✓ |
| | 216-EL | 12" | 27" | 8" | 16" | 31" | 12 1/2" | 27 1/2" | 8 1/4" | 1/4" | 20 | ✓ |
| | 217-EL | 12" | 27" | 8" | 16" | 31" | 12 1/2" | 27 1/2" | 8 1/4" | 1/4" | 20 | ✓ |
| | 218-EL | 12" | 27" | 8" | 16" | 31" | 12 1/2" | 27 1/2" | 8 1/4" | 1/4" | 20 | ✓ |
| Fully-Recessed | | | | | | | | | | | | |
| | 526-EL | 8" | 17" | 5" | 12" | 21" | 8 1/4" | 17 1/4" | 4 3/4" | 1/4" | 5 | ✓ |
| | 527-EL | 8" | 17" | 5" | 12" | 21" | 8 1/4" | 17 1/4" | 4 3/4" | 1/4" | 5 | ✓ |
| | 528-EL | 8" | 17" | 5" | 12" | 21" | 8 1/4" | 17 1/4" | 4 3/4" | 1/4" | 5 | ✓ |
| | 126-EL | 9 1/2" | 24" | 6" | 13 1/2" | 28 1/2" | 10" | 24 1/4" | 6 1/2" | 1/4" | 10 | ✓ |
| | 127-EL | 9 1/2" | 24" | 6" | 13 1/2" | 28 1/2" | 10" | 24 1/4" | 6 1/2" | 1/4" | 10 | ✓ |
| | 128-EL | 9 1/2" | 24" | 6" | 13 1/2" | 28 1/2" | 10" | 24 1/4" | 6 1/2" | 1/4" | 10 | ✓ |
| | 226-EL | 12" | 27" | 8" | 16" | 31" | 12 1/2" | 27 1/2" | 8 1/4" | 1/4" | 20 | ✓ |
| | 227-EL | 12" | 27" | 8" | 16" | 31" | 12 1/2" | 27 1/2" | 8 1/4" | 1/4" | 20 | ✓ |
| | 228-EL | 12" | 27" | 8" | 16" | 31" | 12 1/2" | 27 1/2" | 8 1/4" | 1/4" | 20 | ✓ |

Installation Options

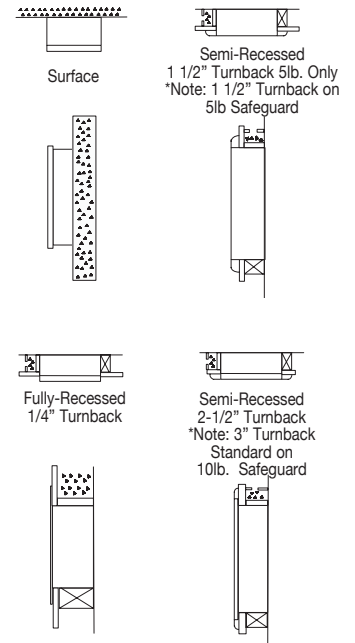

** 316 SS contains 2%-3% molybdenum, added to improve corrosion resistance to chlorides (like sea water).
 304 SS has no molybdenum

✓ADA Compliant

