



PORTABLE/STACKABLE Fire Extinguisher Stand

Detail & Submittal Sheet

Project: _____
 Specification Reference: _____
 Model Number: _____ Quantity: _____
 Architect: _____
 Contractor: _____
 Distributor: _____
 Approved By: _____
 Date: _____

Construction Specifications:

Portable/Stackable Fire Extinguisher Stand (P/S 250) makes it easy to move from jobsite to jobsite. Only 14 lbs. The P/S 250 goes anywhere you need it. This fire extinguisher stand holds 5, 10, or 20 lb. extinguisher and is ideal for construction sites, exhibit halls, workshops or wherever a fire extinguisher is required but cannot be permanently mounted.

Product Features:

- P/S 250 is for 5, 10, and 20 lb. extinguishers which are not included.
- Designed to Nest & Stack.
- Measures 34" in Height
- Actual: 21-1/4" x 21-1/4" x 34"
- 4 FIRE Decals Affixed
- Durable HDPE Red Plastic
- Tip Resistant
- Holds 5, 10, or 20 lb. Extinguishers
- Flame retardant
- Weight: 14 Lbs
- OSHA Compliant
- Mobile, goes wherever you need Extinguishers present,
- Easily cleaned
- No padlock required

Attention CA Residents: Prop 65 Warning This product may contain a chemical known to the State of California to cause cancer and/or birth defects or other reproductive harm. For more information, go to www.p65warnings.ca.gov.



Buy Online 

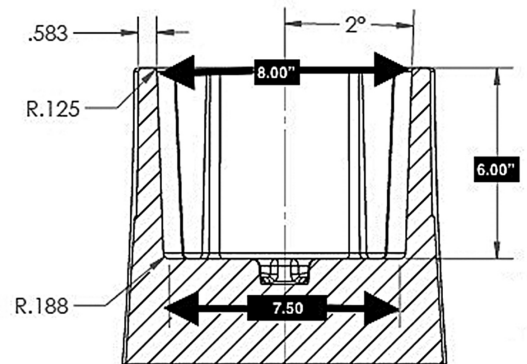

P/S 250
Extinguisher Not Included

✓	Mod. #	Turnback	Interior Storage Size			Overall Area		Carton Amt	Accom. Ext Size Lbs.
			W	H	D	W	H		
Portable/Stackable Fire Extinguisher Stand									
	P/S-250	-	8"	6"	7 1/2"	21 1/4"	34"	1	5, 10, & 20

Fire Extinguisher Not Included

