



# TN-TITAN Aluminum Series Fire Extinguisher Cabinets (Non-Rated)

## Detail & Submittal Sheet

### Construction Specifications:

Titan Aluminum Series cabinets are constructed of non-extruded .063 thick aluminum with grey finish powder coat. All non-rated cabinets come standard with steel tubs, chrome steel handles and clear acrylic glazing.

To comply with ADA Guidelines, Extinguishers and Cabinets offer handles, brackets and turnbacks according to instructions provided by installer. For ADA compliance follow the specification ordering process dimensions in our catalog. Proper installation in accordance with the ADA Guidelines is the sole responsibility of the installer. For more information please visit the Accessibility Guidelines for Buildings and Facilities website or call them at 1-800-872-2253.



Project: \_\_\_\_\_  
 Specification Reference: \_\_\_\_\_  
 Model Number: \_\_\_\_\_ Quantity: \_\_\_\_\_  
 Architect: \_\_\_\_\_  
 Contractor: \_\_\_\_\_  
 Distributor: \_\_\_\_\_  
 Approved By: \_\_\_\_\_  
 Date: \_\_\_\_\_

### SPECIFICATION PROCESS: Follow the steps below to specify your cabinet.

- STEP 1: EXTINGUISHER SIZE:**  
 5 - 5 lb. 1 - 10 lb. 2 - 20 lb.
- STEP 2: CABINET STYLE:**  
 0 - Surface Mounted (S)  
 1 - Semi-Recessed (SR)  
 2 - Fully-Recessed (FR)
- STEP 3: DOOR STYLE:**  
 6 - Full Glass (FG)  
 7 - Full Metal (FM)  
 8 - Vertical Duo (VD)
- STEP 4: SERIES:**  
 TN - Aluminum Cabinet
- STEP 5: CABINET TYPE:**  
 Non-Fire Rated
- STEP 6: FINISH (Standard):**  
 **FAL** - Full Aluminum w/Baked Grey Enamel (Standard)

- FALR** - Full Aluminum w/Baked Red Enamel (Standard)
- FALB** - Full Aluminum w/Baked Black Enamel (Standard)
- STEP 7: HANDLE/ACCESSORY OPTIONS:**  
 **007** - Chrome "D" Handle (Standard)  
 **008** - Chrome "D" Handle w/Safety Break Glass  
 **010** - Aluminum Die Cast Red "Fire" Handle  
 **012** - ADA "Recessed" Handle
- STEP 8: GLAZING:**  
 **G11** - Clear Acrylic (standard)  
 **G12** - Clear Tempered Glass
- STEP 9: LETTERING:**  
 **004** - Decal "Fire Ext." Vertical R/B

### Options



## BuyOnline

### How to Measure a Cabinet

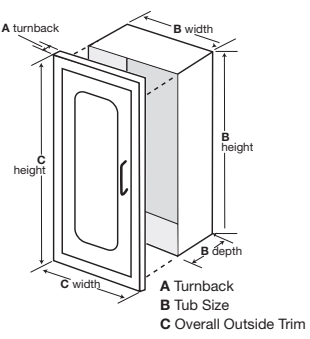

| ✓                      | Mod. # | Interior Tub Size |     |    | Overall Outside Trim |         | Rough Opening |         |        | Turnback | Accom. Ext Size<br>Lbs. |   |
|------------------------|--------|-------------------|-----|----|----------------------|---------|---------------|---------|--------|----------|-------------------------|---|
|                        |        | W                 | H   | D  | W                    | H       | W             | H       | D      |          |                         |   |
| <b>Surface Mounted</b> |        |                   |     |    |                      |         |               |         |        |          |                         |   |
|                        | 506-TN | 8"                | 17" | 5" | 8 1/2"               | 17 1/2" | -             | -       | -      | -        | 5                       | ✓ |
|                        | 507-TN | 8"                | 17" | 5" | 8 1/2"               | 17 1/2" | -             | -       | -      | -        | 5                       | ✓ |
|                        | 508-TN | 8"                | 17" | 5" | 8 1/2"               | 17 1/2" | -             | -       | -      | -        | 5                       | ✓ |
|                        | 106-TN | 9 1/2"            | 24" | 6" | 10"                  | 24 1/2" | -             | -       | -      | -        | 10                      | ✓ |
|                        | 107-TN | 9 1/2"            | 24" | 6" | 10"                  | 24 1/2" | -             | -       | -      | -        | 10                      | ✓ |
|                        | 108-TN | 9 1/2"            | 24" | 6" | 10"                  | 24 1/2" | -             | -       | -      | -        | 10                      | ✓ |
|                        | 206-TN | 12"               | 27" | 8" | 12 1/2"              | 27 1/2" | -             | -       | -      | -        | 20                      | ✓ |
|                        | 207-TN | 12"               | 27" | 8" | 12 1/2"              | 27 1/2" | -             | -       | -      | -        | 20                      | ✓ |
|                        | 208-TN | 12"               | 27" | 8" | 12 1/2"              | 27 1/2" | -             | -       | -      | -        | 20                      | ✓ |
| <b>Semi-Recessed</b>   |        |                   |     |    |                      |         |               |         |        |          |                         |   |
|                        | 516-TN | 8"                | 17" | 5" | 10 3/4"              | 19 3/4" | 10"           | 19"     | 4 1/2" | 1 3/4"   | 5                       | ✓ |
|                        | 517-TN | 8"                | 17" | 5" | 10 3/4"              | 19 3/4" | 10"           | 19"     | 4 1/2" | 1 3/4"   | 5                       | ✓ |
|                        | 518-TN | 8"                | 17" | 5" | 10 3/4"              | 19 3/4" | 10"           | 19"     | 4 1/2" | 1 3/4"   | 5                       | ✓ |
|                        | 116-TN | 9 1/2"            | 24" | 6" | 13 1/2"              | 28 1/2" | 9 3/4"        | 24 1/4" | 3 1/2" | 2 1/2"   | 10                      | ✓ |
|                        | 117-TN | 9 1/2"            | 24" | 6" | 13 1/2"              | 28 1/2" | 9 3/4"        | 24 1/4" | 3 1/2" | 2 1/2"   | 10                      | ✓ |
|                        | 118-TN | 9 1/2"            | 24" | 6" | 13 1/2"              | 28 1/2" | 9 3/4"        | 24 1/4" | 3 1/2" | 2 1/2"   | 10                      | ✓ |
|                        | 216-TN | 12"               | 27" | 8" | 16"                  | 31"     | 12 1/4"       | 27 1/4" | 5"     | 3"       | 20                      | * |
|                        | 217-TN | 12"               | 27" | 8" | 16"                  | 31"     | 12 1/4"       | 27 1/4" | 5"     | 3"       | 20                      | * |
|                        | 218-TN | 12"               | 27" | 8" | 16"                  | 31"     | 12 1/4"       | 27 1/4" | 5"     | 3"       | 20                      | * |
| <b>Fully-Recessed</b>  |        |                   |     |    |                      |         |               |         |        |          |                         |   |
|                        | 526-TN | 8"                | 17" | 5" | 12"                  | 21"     | 8 1/4"        | 17 1/4" | 4 3/4" | 1/4"     | 5                       | ✓ |
|                        | 527-TN | 8"                | 17" | 5" | 12"                  | 21"     | 8 1/4"        | 17 1/4" | 4 3/4" | 1/4"     | 5                       | ✓ |
|                        | 528-TN | 8"                | 17" | 5" | 12"                  | 21"     | 8 1/4"        | 17 1/4" | 4 3/4" | 1/4"     | 5                       | ✓ |
|                        | 126-TN | 9 1/2"            | 24" | 6" | 13 1/2"              | 28 1/2" | 10"           | 24 1/4" | 6 1/2" | 1/4"     | 10                      | ✓ |
|                        | 127-TN | 9 1/2"            | 24" | 6" | 13 1/2"              | 28 1/2" | 10"           | 24 1/4" | 6 1/2" | 1/4"     | 10                      | ✓ |
|                        | 128-TN | 9 1/2"            | 24" | 6" | 13 1/2"              | 28 1/2" | 10"           | 24 1/4" | 6 1/2" | 1/4"     | 10                      | ✓ |
|                        | 226-TN | 12"               | 27" | 8" | 16"                  | 31"     | 12 1/2"       | 27 1/2" | 8 1/4" | 1/4"     | 20                      | ✓ |
|                        | 227-TN | 12"               | 27" | 8" | 16"                  | 31"     | 12 1/2"       | 27 1/2" | 8 1/4" | 1/4"     | 20                      | ✓ |
|                        | 228-TN | 12"               | 27" | 8" | 16"                  | 31"     | 12 1/2"       | 27 1/2" | 8 1/4" | 1/4"     | 20                      | ✓ |

### Installation Options

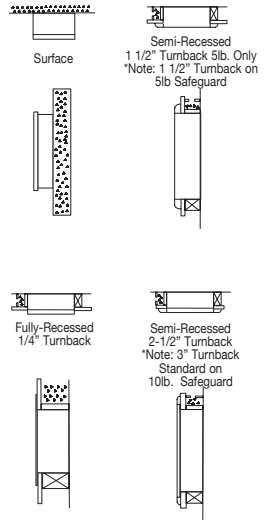

\*ADA Recessed Handle required ✓ADA Compliant

